

Reservoir Valve Block

Reservoir Valve Block

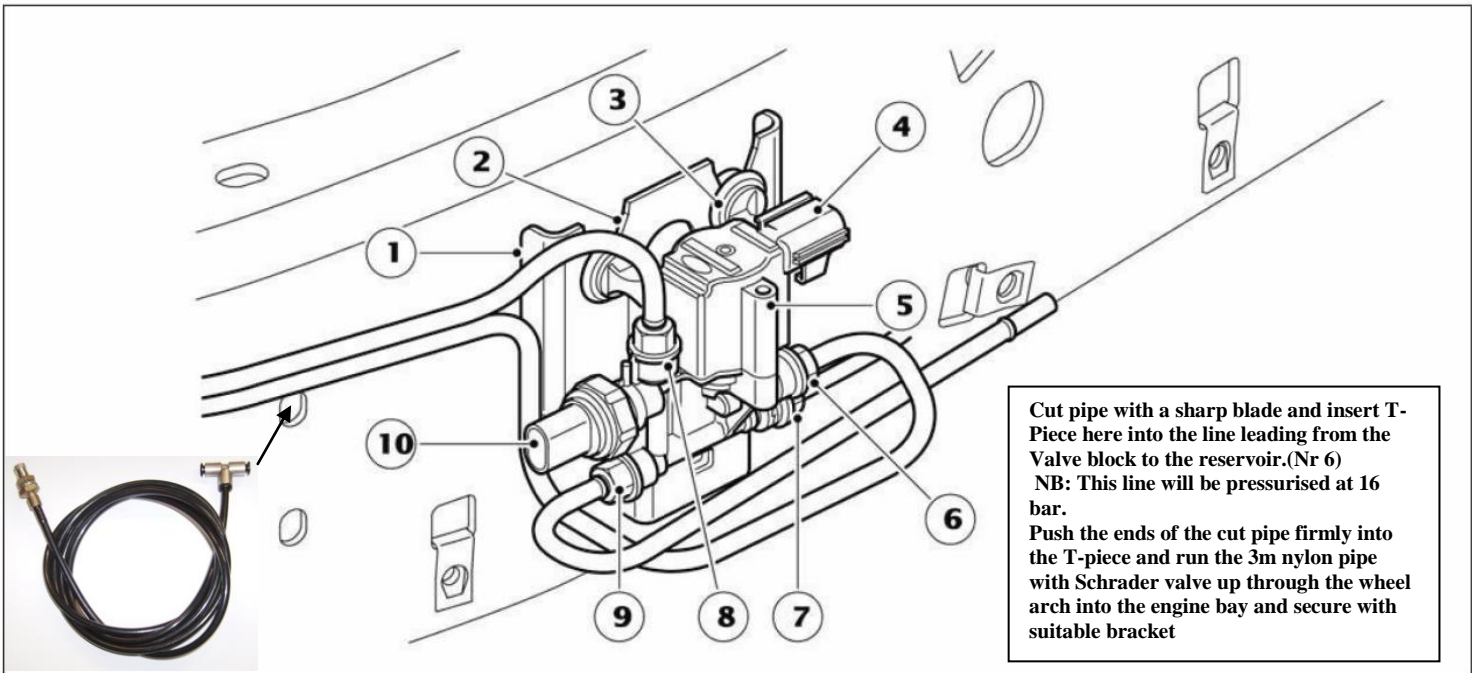

Item	Description	Item	Description
1.	Chassis mounting bracket	6.	Reservoir connection
2.	Location slot	7.	Rear valve block connection
3.	Isolation rubber mounts (3 off)	8.	Front valve block connection
4.	Electrical connector	9.	Air supply unit connection
5.	Reservoir valve block, valves and solenoid assembly	10.	Pressure sensor